

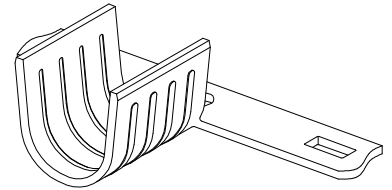

Bu Çizim MESA OTO ELEKTRİK LTD.ŞTİ'nin malıdır. Şirket Yetkilerinin izni olmaksızın kopya edilemez, üzerinde değişiklik yapılamaz.
This Drawing MESA AUTO ELECTRIC LTD 's are property. Can not be copied without the consent of the company authorized, any changes can be made.

| PARÇA KODU PART CODE | PARÇA ADI PART NAME | s ÖLÇÜSÜ (KALINLIK) s MEASURE (THICKNESS) | Malzeme Material | Kaplama / Coating | | |
|-------------------------|-------------------------------|--|-------------------------|-------------------|----|----|
| | | | | SN | AG | Ni |
| TEK 2861 RP | EK BİRLEŞTİRME (TKT 88) =RP= | ----- | (CuZn30) Pirinç / Brass | - | - | - |
| TEK 2861 RPK | EK BİRLEŞTİRME (TKT 88) =RPK= | ----- | (CuZn30) Pirinç / Brass | + | - | - |

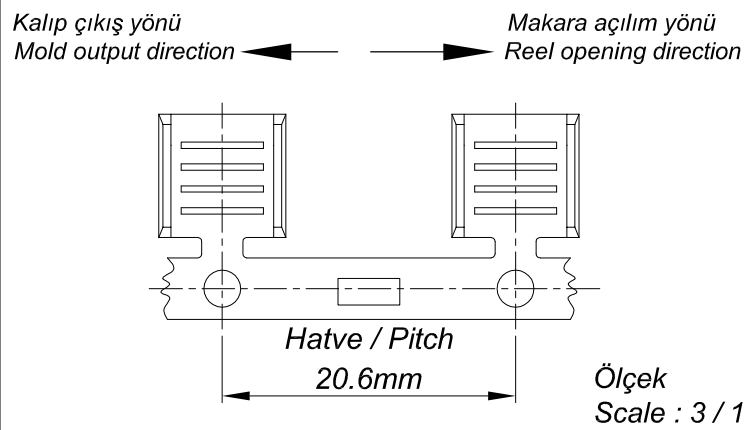
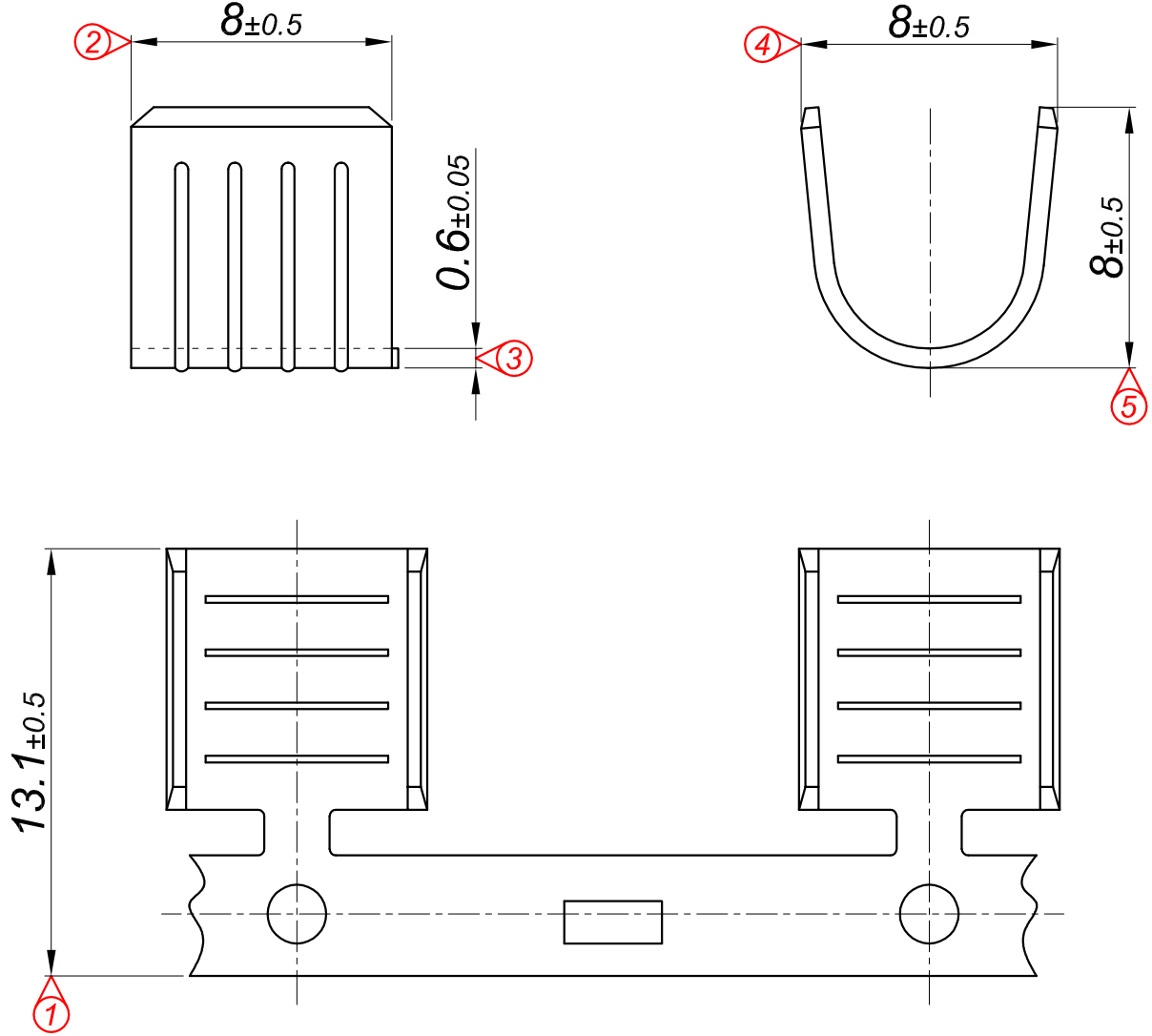

Kablo Kesiti
Wire Section : 6 - 8 mm²

Resmin Üzerinden Ölçü Almayınız
Don't use the drawing for measuring purpose

| | | | | | |
|---|-------------------------|-------------------------|--------------------------|-----------------------|------------|
| Tarih / Date | 28.11.2013 | İmza / Signature | Ölçek / Scale | | |
| Çizen / Desing | M.Yağcı | | 5 / 1 | | |
| Onay / Approval | S.Gölcük | | No | Değişiklik / Revision | Tarih/Date |
|  | Parça Adı: Part Name | EK BİRLEŞTİRME (TKT 88) | Parça Kodu: Part Code | TEK 2861 | |